

LOC	Q1ST	P	F	ZONE	LTR	REVISIONS	DESCRIPTION	DATE	APPD
G	14					0	RELEASED PER 0720-0008-93	2-2-93	JL DAP

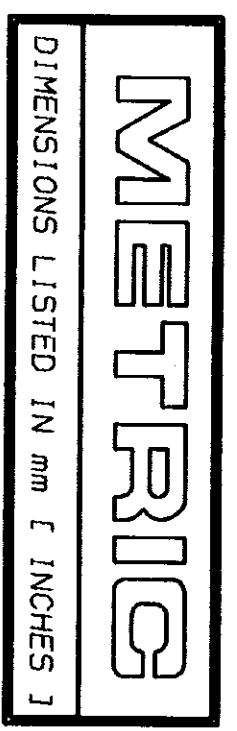

AMP WIRE RANGE 26-22 AWG STRANDED	JL E13288 Listed	NOT LISTED
LR7189 Certified	MILITARY P/N AND CLASS	NOT APPLICABLE
NOT CERTIFIED		NOT APPLICABLE

△ STAMP AMP APPROX AS SHOWN

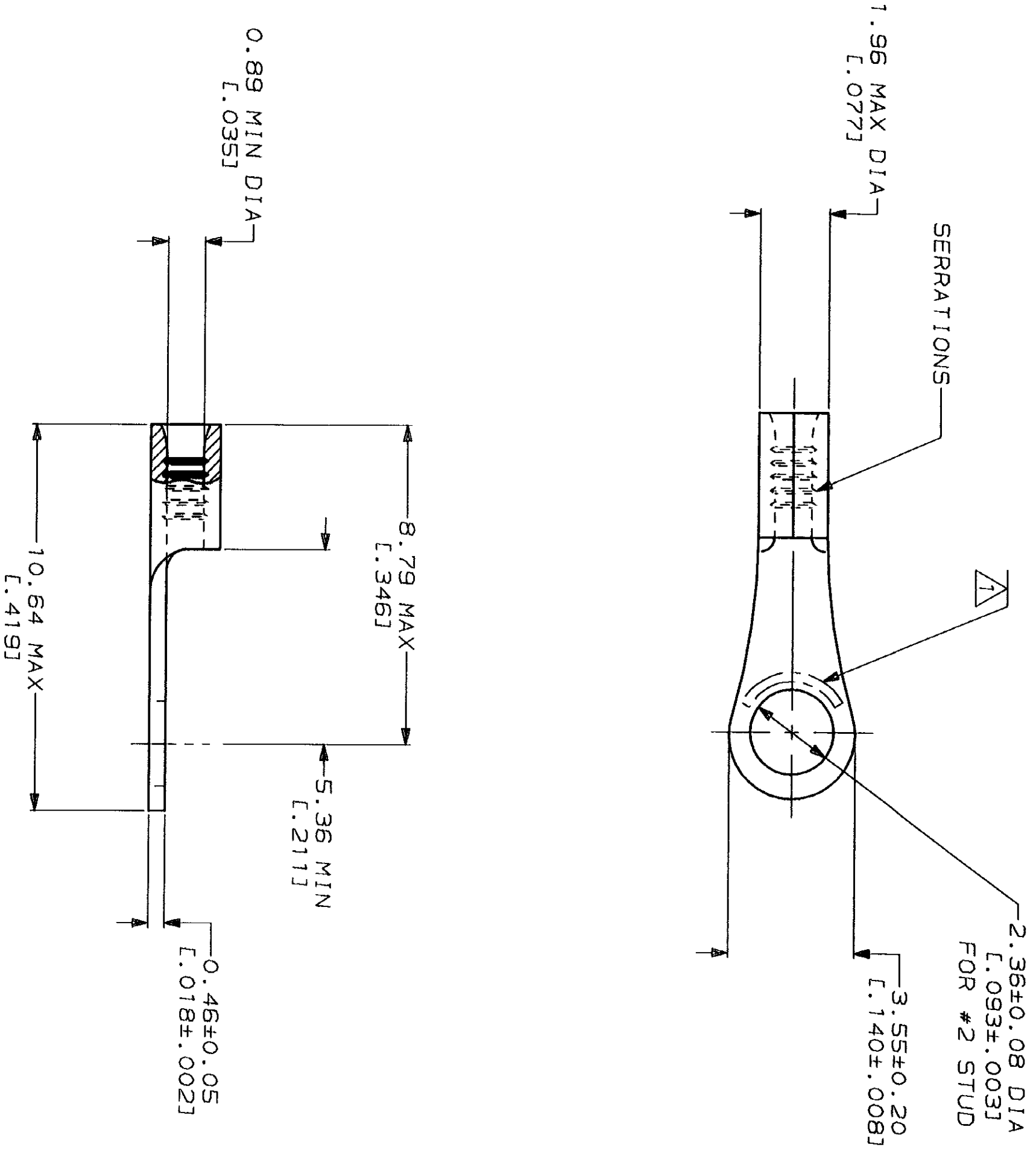

AMP INCORPORATED
CUSTOMER SERVICE SYSTEMS

FOR ADDITIONAL PRODUCT INFORMATION OR COPIES OF DRAWINGS AND TECHNICAL DOCUMENTS
 1-800-522-6752
 PRODUCT INFORMATION CENTER

FOR APPLICATION TOOLING INFORMATION
 1-800-722-1111
 TOOLING ASSISTANCE CENTER

FOR ORDER ENTRY
 1-800-526-5142
 TOOLING INFORMATION

MAX RECOMMENDED OPERATING TEMPERATURE:
170°C MAX

VOLTAGE RATING:
NOT APPLICABLE

WIRE CROSS SECTIONAL AREA RANGE:
0.1-0.41mm² [202-810] CIR MILS
STRANDED

THIS DRAWING IS A CONTROLLED DOCUMENT FOR AMP INCORPORATED. IT IS SUBJECT TO CHANGE AND THE CONTROLLING ENGINEERING ORGANIZATION SHOULD BE CONSULTED FOR THE LATEST REVISION.

DO NOT SCALE PRINT. UNLESS SPECIFIED DIMENSIONS IN mm [INCHES] TOLERANCES ON:
 2 PLG DEC ±
 3 PLG DEC ±
 ANGLES

MATERIAL
 COPPER PER ASTM B-152
 ANNEALED

FINISH
 TIN PLATE
 0.00254 [0.00100] MIN THK PER MIL-T-10727

DR 2-2-93 TA BRINKMAN	CHK 2-2-93 DA PATTERSON	APPD 2-2-93 DE MILLER
APPD 2-2-93 JL MECKLEY	PRODUCT SPEC	APPLICATION SPEC

WEIGHT -



AMP Incorporated
 Harrisburg, PA 17105-3608

NAME
AMP
 TERMINAL, RING
 TONGUE, BUDGET

SIZE
 CAGE CODE
 00779
 DRAWING NO
 322771

322771
 PART NO